

Degson Double Decker Terminals – DC Series

Specifications

Screw type Din-Rail TB
 Current carriers: Copper
 Screw/Cage: Steel
 Housing: PA66 UL94V-0
 Connection type: Screw connection
 Open-end side panels: Yes
 Number of connections: 4
 Number of potentials: 2
 Colour: Grey
 Mounting type: NS 35/7.5, NS35/15
 Manufacturer: Degson

Product image

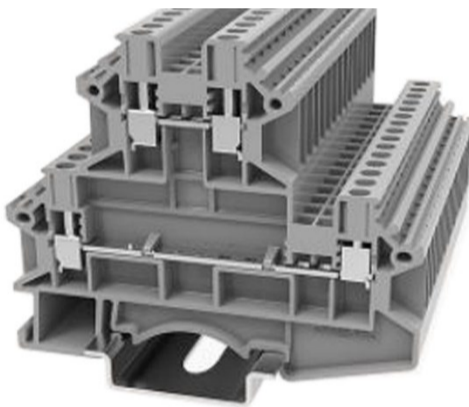

Product advantages

- Screw connection technology, reliable connection
- Equipped with dual-channel bridge wells, circuit connection testing is more flexible
- Double-layer structure saves wiring space
- Unique plug-in bridge, high circuit connection efficiency
- The box has a baffle to prevent mis-insertion
- Can be matched with terminal markers to avoid incorrect insertion of wires

Product Certifications



Product details

Part No.	Cross Section	AWG	H (mm)	W (mm)	Length (mm)
DCKKB4	0.2mm ² - 4mm ²	26 - 12	61.75	6.1	76

Product Dimensions

DCKKB4

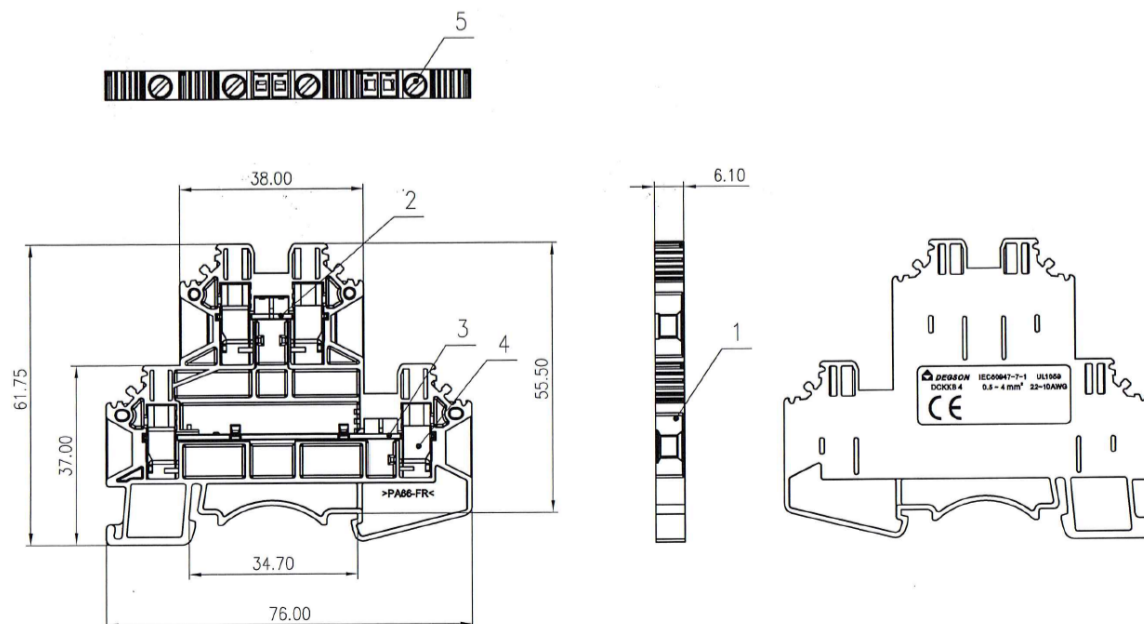

Subject to change without notice